

Greeting Cards Activity Pack

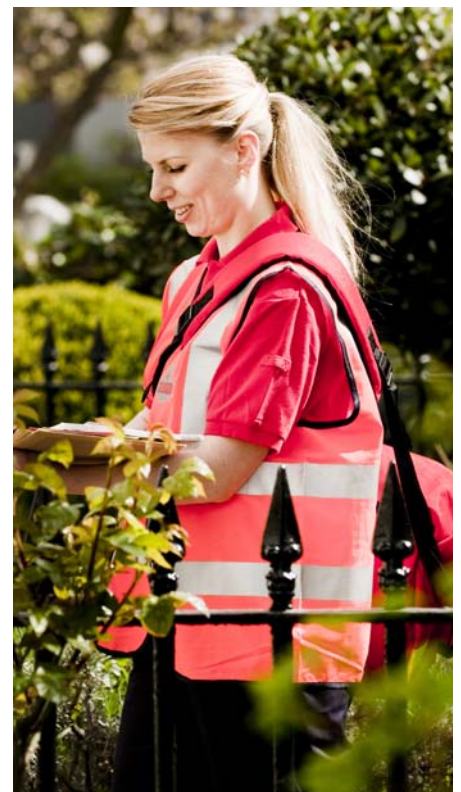

greeting cards activity pack

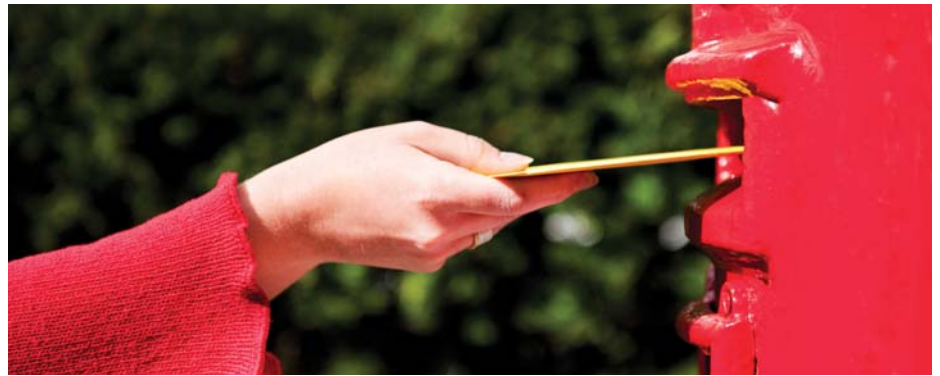

Contents

| | |
|--|----|
| Introduction | 2 |
| Activity themes | |
| 1. Cards for Special Occasions | 4 |
| 2. Cards for Festivals | 5 |
| 3. Greetings and Rhymes for Cards | 6 |
| 4. Postal Charges for Cards | 7 |
| 5. Designing and Making Cards | 8 |
| Photocopy masters | |
| Photocopy Master Sheet 1 | 9 |
| Photocopy Master Sheet 2 | 10 |
| Photocopy Master Sheet 3 | 11 |
| Photocopy Master Sheet 4 | 12 |



Introduction

The following theme plans use greeting cards as the stimulus for a range of cross-curricular activities that have relevance for children aged 5 to 11 throughout England, Northern Ireland, Scotland and Wales.

Through participating in the activities children will have the opportunity to:

- develop their knowledge and understanding of different faith groups and nationalities within their school community
- write rhymes/greetings for a variety of purposes
- handle data
- develop their knowledge and understanding of money and measuring
- develop an understanding of the importance of written social communication
- use written communication to reinforce friendship and develop social skills
- enjoy creativity, exploring, generating ideas, designing and making greeting cards

Sharon Little,
Chief Executive, Greeting Card Association

Barry Wiles,
Education Manager, Royal Mail Group

Using the plans

The plans can be used as a source of ideas for units of work on communication and celebrations, for 'one-off' lessons on measuring, handling money, writing rhymes and designing and making cards, or for special end-of-term/year activity weeks/days.

Each plan provides learning intentions, a resource list and outline for a number of activities for the given theme. Teachers can adapt the ideas to suit the individual needs of the children they teach and it is left to teachers to decide on the most suitable class within a school for a given activity. Depending upon the way the task is introduced, the level of independence expected of children and the time allowed for each activity can be adapted to suit the individual needs of children throughout the primary age range.

Copy Masters are included on: sizing cards for postal charges, ideas for card making, a design sheet for Design and Technology and one showing how to write 'Happy Birthday' in a variety of languages. In addition, a list of challenges based on greeting cards is given.

The table below indicates the curriculum areas that are the focus for each of the outlined theme plans. Clearly, however, due to the cross-curricular nature of the greeting cards topic the areas of the curriculum promoted will depend on the way teachers use the plans and activities.

| Theme | Faith and Diversity | English | Maths | Design and Technology | Information and Communication Technology |
|--------------------------------|---------------------|---------|-------|-----------------------|--|
| Cards for Special Occasions | ✓ | | | | |
| Cards for Festivals | ✓ | | | | ✓ |
| Greetings and Rhymes for Cards | | ✓ | | | |
| Postal Charges for Cards | | | ✓ | | ✓ |
| Designing and Making Cards | ✓ | ✓ | ✓ | ✓ | ✓ |

greeting cards activity pack

Preparation

Some of the outlined activities require examples of greeting cards. Packs of assorted cards can be ordered from www.teacherspost.co.uk. Alternatively, in the weeks prior to using the activities ask parents/carers to donate unwanted used cards that include a range of celebrations and events.

Up-to-date information on the pricing of stamps for 'letters' and 'large letters' can be found on the Royal Mail website: **Home> Personal Customers> Delivery> Postal prices**

Information on 'letter', 'large letter' and 'packet' formats can also be found online: **Home> Personal Customers> Advice> Our formats explained**

The dimensions chart on Copy Master 1 can also be used to size the cards.

Other resources

A range of educational resources are available from Royal Mail Education, and details of current material can be found on the Teacher's Post website.

www.teacherspost.co.uk

www.greetingcards4schools.org



Theme 1 Cards for Special Occasions

Curriculum focus:

Faith and Diversity

Learning intentions:

Children will appreciate that communities may include a range of nationalities and faith groups. They will become aware that greeting cards may be sent for a wide variety of reasons.

Key vocabulary:

Celebration, festival, sympathy, occasion.

Resources:

Used cards including examples from a range of festivals (e.g. Chinese New Year, Diwali, Eid, Christmas, Easter); celebrations (e.g. good luck, congratulations birthday, wedding anniversary, mothers' day, Valentine's day ...); thank you cards and in sympathy cards. In addition include examples from a range of languages, Copy Master 2.

Introduction:

Show the children a selection of greeting cards. Together explore similarities and differences in the cards. Consider why the cards were made and sent; the pictures on the cards; the use of greetings/ rhymes/phrases; special design features such as ribbons, glitter, 'pop-up' form; language.

Activities:

- Give small groups about 10 cards. Explain that greeting cards in shops tend to be organised in themes. Ask the children to sort the cards into groups using different criteria. Then ask them to make a list of the criteria they used. As a class talk about the criteria and decide which ones might work well in a card shop for organising the stock.
- In the hall place children in groups of three, each with 10 cards. Call out clues for cards such as 'A card that has a greeting not written in English'; 'A card sent for a festival'; 'A card suitable for a new baby' ... Play a game in which a point is given to each group that can produce a card to fit the clue. In addition an extra point is given to the group that is first to produce a card.
- Involve the children in making a display of cards. Encourage them to use ICT to make labels for the display that will encourage people to look at the display and to appreciate the wide variety of cards that are sent.
- Make a card timeline with birthday cards arranged according to their birthday age (e.g. '1 today', 'Happy Birthday 2 years old!' etc.).
- Make a role play greeting card shop. Invite the children to take on the role of both customer and shop assistant.

Theme 2 Cards for Festivals

Curriculum focus:

Faith and Diversity, ICT

Learning intentions:

Children will understand that there are a variety of religious festivals.

Key vocabulary:

Names for festivals e.g. Christmas, Chinese New Year, Chanukah, Diwali, Eid, Easter.

Resources:

Cards for a range of festivals, pictures/photos of people celebrating festivals.

Introduction:

Invite carers and/or children to show a card they have received during a religious festival they enjoy celebrating. Talk about special symbols or messages used within each card. Ask the carers/children to explain how they celebrate the festival.

Activities:

- Arrange the cards in month order to show when the festivals happen over the course of the year. Identify the festivals that will happen the following year on the same dates and those that vary dependent on factors such as when there is a full moon.
- Use ICT to research facts about festivals depicted in the cards. Make a festival display of the cards and facts.

Theme 3 Greetings and Rhymes for Cards

Curriculum focus:

English

Learning intentions:

Children will write rhymes and greetings for cards.

Key vocabulary:

Rhyme, greeting, message.

Resources:

Examples of birthday cards, some containing rhymes.

Introduction:

Show the children the examples of birthday cards. Examine each one. Consider the front and the words inside. Explain that sometimes people choose or do not choose a card because of what the words say. Talk about how it feels to receive a card.

Activities:

- Sort the cards according to the writing inside. Ask the children to describe people who might like to receive a given card. Invite them to select a card with a message/rhyme they do not like. Encourage the children to rewrite the message/rhyme.
- Compare the birthday rhymes. Encourage the children to analyse critically the rhythm, the word choice and the message. Ask each group to choose a rhyme to present to the class.
- Make a word bank of rhyming words that could be used when writing rhymes for birthday cards.
- Write a birthday acrostic in which a word or phrase is written for each letter in 'HAPPY BIRTHDAY'. Alternatively write an acrostic for a festival.
- Challenge the children to write a new birthday rhyme for a given children's age group (e.g. 10 years old). Encourage them to use ICT to present their rhymes. If appropriate, reproduce the rhymes in cards to raise funds for the school or a charity chosen by the children.
- Ask the children to write and 'send' a card with a friendly message to a friend in the class. Discuss how it feels to receive a card from a friend. Would it be the same if your friend had just told you the same thing? (One of the differences is you can keep and treasure a card.)
- Suggest other festivals and occasions when we might send a card.

Theme 4 Postal Charges for Cards

Curriculum focus:

Maths, ICT

Learning intentions:

Children will select the postal charge for sending given cards within the United Kingdom. They will understand the factors that affect the postal charges such as mass, size and destination.

Key vocabulary:

United Kingdom, measure, size, price, 'letter', 'large letter'.

Resources:

Copy Master 1; Royal Mail pricing chart or interactive white board and internet access; examples of cards of different sizes; letter scales.

Introduction:

Use the Royal Mail interactive demonstration of mail formats (**Home > Personal Customers > Advice > Our formats explained**) on an interactive white board. Explain how the size of the card, its mass and the country to which it is being sent will affect the postage stamp it needs to take it to a given destination.

Activities:

- Estimate the sizes of cards. Use Copy Master 1 to sort the cards as 'letters' or 'large letters'.
- Use rulers to measure card lengths and widths in millimetres.
- Challenge the children to use recyclable materials such as cereal packets to make resources that could be used to size cards (e.g. slits to check letter depths, templates measured accurately). Remind the children that the thickness as well as the length, width and weight of the card in its envelope are relevant.
- Find the mass in grams of a variety of cards in envelopes. Arrange them in mass order and state what stamp they would need for a given destination.
- Write a 'stamp multiplication table' (e.g. 1 X a first class stamp =) Challenge the children to find an answer in the 'first class table' that is the same as one in the table for second class stamps.

Theme 5 Designing and Making Cards

Curriculum focus:

Design and Technology, Art, English, ICT, Maths

Learning intentions:

Children will design and make cards for a given occasion.

Key vocabulary:

Names for festivals, occasions and materials.

Resources:

Design sheets (see Copy Masters 3 and 4); examples of cards made in a variety of styles (e.g. pop-up/out; cards with badges; decoupage; cards with added features such as glitter, feathers, ribbon or sequins); details of card prices; calculators; glue, scissors and materials requested by the children to make their cards.

Introduction:

Show the children the cards. Invite them to say what they like or dislike about a given card. Encourage the children to consider how it is made, the likely audience for the card and whether it offers value for money. Together make a list of features that would make an ideal card. Encourage the children to justify the features in the list.

Activities:

- Design a birthday card that costs no more than a given amount to produce. Provide calculators for children to price their chosen materials.
- Design and make a card with a moving part that could be posted at the 'letter' rate.
- Design and make a pop-up card that weighs as little as possible. Identify the lightest card in the class.
- Design and make a card from recyclable materials for a given festival.
- Use ICT to word process greetings and messages in different fonts and sizes for the cards.

Card challenges:

- Find a card and envelope that weigh exactly 50 grams.
- Find the lightest card.
- Find the largest card.
- Find a card made entirely from recycled materials.
- Make a class encyclopaedia of ideas for card making.
- Find words to rhyme with each number from one to 10 that could be used in birthday card rhymes. Sort the words into nouns, adjectives, verbs, other.
- Make a patchwork collage of cards for different occasions. Each card placed on the board must not replicate other occasions already represented. Use the patchwork to play 'I spy a card that ...' and for data handling.
- Use maps and ICT to find distance records such as 'If we posted a card with a first class stamp the furthest destination it could be sent to from here is ...'

lesson activities: COPY MASTER 1

Dimensions and weight limits

| Letter | |
|------------|-----------|
| Length: | 240mm max |
| Width: | 165mm max |
| Thickness: | 5mm max |
| Weight: | 100g max |

For example: most cards, postcards and bills

| Large Letter | |
|--------------|-----------|
| Length: | 353mm max |
| Width: | 250mm max |
| Thickness: | 25mm max |
| Weight: | 750g max |

For example: most A4 documents, CDs and magazines

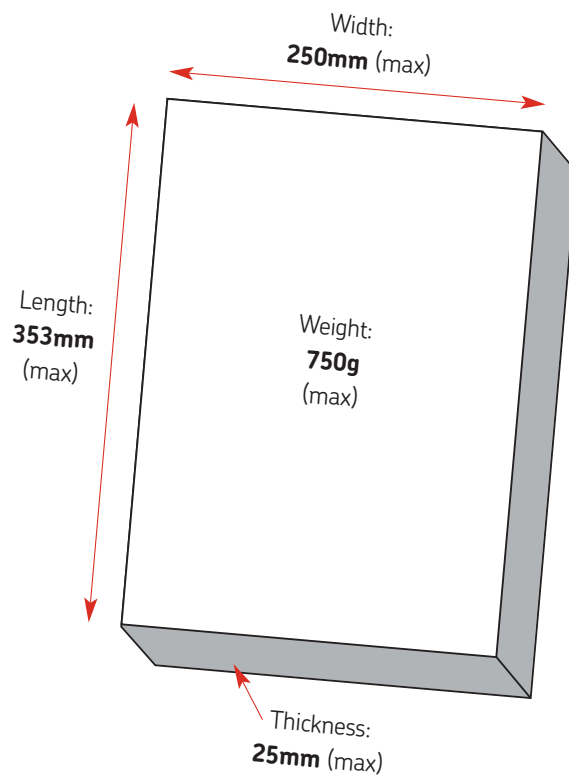
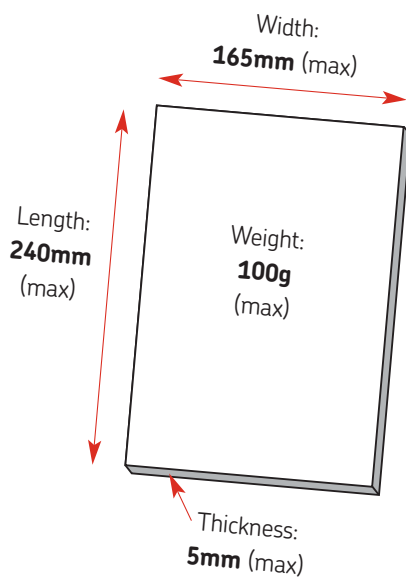

lesson activities: COPY MASTER 2

'Happy Birthday' in a variety of languages

Arabic
(Modern Standard)

سعيد ميلاد عيد بخير أنت و عام كل

Chinese
(Mandarin)

生日快樂

French

Bon anniversaire

German

Alles gute zum Geburtstag

Japanese

お誕生日おめでとうございます

Scottish Gaelic

Là breith sona dhuit

Spanish

¡feliz cumpleaños

Welsh

Penblwydd Hapus

Polish

Wszystkiego najlepszego

Urdu

مبارک سال گِر

Hindi

जन्मदिन मुबारक हो

Ideas for card making

1 Pop-up cards - simple pop-ups

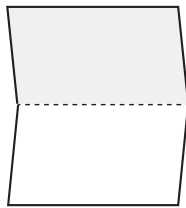

Fold in half

Cut and push in

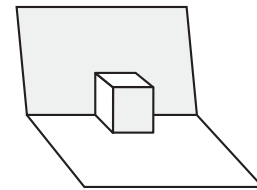
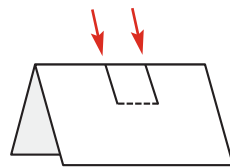

Pop-up on which to stick a picture

2 Beak/mouth pop-out

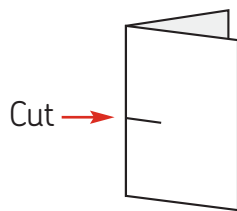

Fold paper in half and cut through the fold

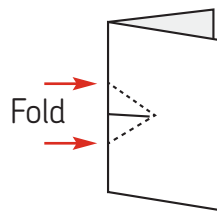

Fold triangular flaps outwards then push flaps in

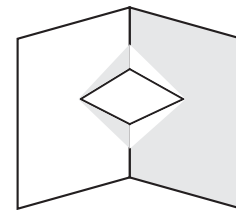

3 Push pull cards

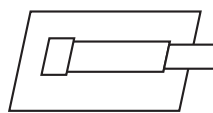
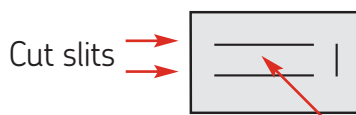

Insert strip and pull

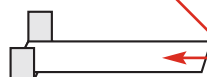

Distance is strip width

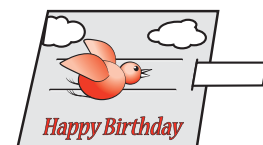

4 Split pin cards

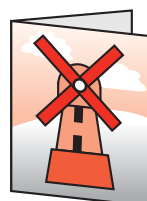

lesson activities: COPY MASTER 4

Card designer's name:

Occasion for which the card will be made:

Person who will receive the card:

Design ideas for the front

Design ideas for the inside

Materials I will need

greeting cards activity pack

Acknowledgements:

Author: Rachel Sparks Linfield
Designer: Paula Sayer
Project management: Magenta Project Management Ltd **01353 741222**

Royal Mail Education
Education House
Castle Road
Sittingbourne
Kent
ME10 3RL

Telephone: **01795 426465**
Web: www.teacherspost.co.uk
Email: royalmail@edist.co.uk

Greeting Card Association
United House
North Road
London
N7 9DP

Telephone: **020 7619 0396**
Web: www.greetingcardassociation.org.uk
www.greetingcards4schools.org
Email: gca@max-publishing.co.uk

Royal Mail, the Cruciform and the colour red, are trademarks of Royal Mail Group Ltd.
This Greeting Card Activity Pack is © Royal Mail Group Ltd 2011. All rights reserved.

